

## XC5 Accessories

### Press-fit Tool (XY2D-1005)

- Hand-operated tool designed especially for mounting Fine-fit Connectors to a board.
- Hand-operated for ease and safety.
- The Press-fit Tool User's Manual must be ordered separately.

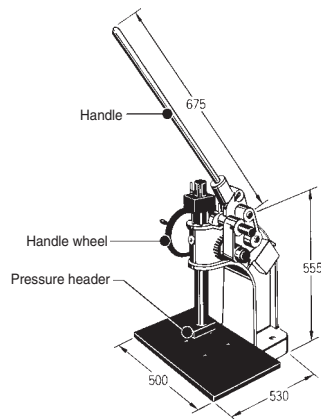

### Specifications

Applicable Connectors	XC5□-□□□P Fine-fit
Max. pressure	2 t
Stroke (max.)	8 mm (handle) 283 mm (handle wheel)
Weight	80 kg
Base area	500 mm × 530 mm

### Model

Model	XY2D-1005
-------	-----------

### Contact Repair Tools

- The tool works on top of the Connector.
- This tool is used for correcting mistakes made with the Press-fit Tool. (plugs only)
- For details on use, see the Fine-fit Connector Press-fit Tool User's Manual. The User's manual must be ordered separately.

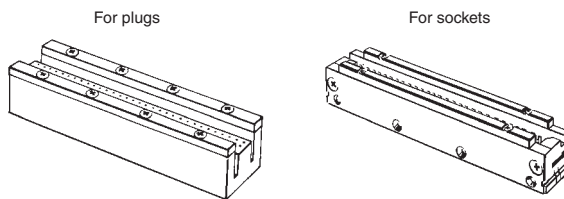

### For Plugs

Rows	No. of contacts	Model
Double rows (XC5E)	32	XY2D-1007
	64	XY2D-1006
	100	XY2D-1035
Triple rows (XC5G)	48	XY2D-1009
	96 (64)	XY2D-1008

### For Sockets

Rows	No. of contacts	Model
Double rows (XC5B)	32	XY2D-1011
	64	XY2D-1010
	100	XY2D-1036
Triple rows (XC5D)	48	XY2D-1013
	96 (64)	XY2D-1012

### Support Block and Plungers

- The Support Block and Plungers (2) are set on top of the base board.
- The Support Block is used to protect the fine-fit pins while the Press-fit Tool is being used.
- The Plunger is inserted into the mounting holes. It functions as a positioner for the Connector and cushions the Contact Repair Tool.

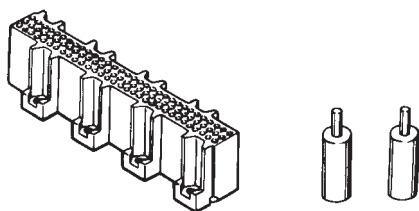

### Support Blocks

Rows	No. of contacts	Model
Double rows	64	XY2D-1014
Triple rows	96	XY2D-1015

**Note:** Cut the XY2D-1014 when using Double-row Connectors with 100 or 32 contacts. Cut the XY2D-1015 when using Triple-row Connectors with 100 or 32 contacts (no center row).

### Plungers

Applicable board thickness	Model
1.6 to 3.2 mm	XY2D-1017

### Setting the Repair Tool, Support Block, and Plunger

- Base board is not supplied by OMRON.
- The base board including the Support Block and Plunger are collectively called the Support Assembly.
- Place the circuit board on top of the Support Assembly and place the whole thing on the Press-fit Tool.
- Insert the Fine-fit Connectors into the board one at a time by moving the Support Assembly left and right.

